

Reach truck 1.2 - 1.6 ton

BT reflex

B-series

RRE120B

RRE140B

RRE160B



Reach truck

Truck specifications					RRE120B	RRE140B	RRE160B
Identification	1.1	Manufacturer			BT	BT	BT
	1.2	Model			RRE120B	RRE140B	RRE160B
	1.3	Drive			Electric	Electric	Electric
	1.4	Operator type			Seated	Seated	Seated
	1.5	Load capacity/rated load	Q	kg	1200	1400	1600
	1.6	Load centre	c	mm	600	600	600
	1.8	Load distance, centre of support arm wheel to face of forks	x	mm	415	415	343
	1.9	Wheelbase	y	mm	1440	1440	1440
	Weight	2.1	Service weight including battery		kg	2446	2753
2.3		Axle load, mast retracted without load, drive/support arm wheel		kg	1531/915	1700/1053	1804/1147
2.4		Axle load, mast extended with load, drive/support arm wheel		Kg	444/3205	502/3657	492/4068
2.5		Axle load, mast retracted with load, drive/support arm wheel		Kg	1388/2261	1440/2718	1489/3070
Wheels		3.1	Drive/support arm wheel			Vulkollan®	Vulkollan®
	3.2	Wheel size, front		mm	Ø 330	Ø 330	Ø 330
	3.3	Wheel size, rear		mm	Ø 280	Ø 280	Ø 280
	3.5	Wheels, number front/rear (x=driven wheels)			1x/2	1x/2	1x/2
	3.7	Track width, rear	b ₁₁	mm	1134	1134	1134
	Dimensions	4.1	Tilt of fork, forward/backward	α/β	deg	4°/-2°	4°/-2°
4.2		Height, mast lowered	h ₁	mm	2182	2182	2182
4.3		Free lift	h ₂	mm	1550	1550	1550
4.4		Lift	h ₃	mm	4760	4760	4760
		Lift height	h ₂₃	mm	4800	4800	4800
4.5		Height, mast extended	h ₄	mm	5432	5432	5432
4.7		Height of overhead guard (cab)	h ₆	mm	2153	2153	2153
4.8		Seat height	h ₇	mm	1075	1075	1075
4.10		Height of support arms	h ₈	mm	245	245	245
4.15		Height of lowered forks	h ₁₃	mm	55	55	55
4.19		Overall length	l ₁	mm	2364	2364	2436
4.20		Length to face of forks	l ₂	mm	1214	1214	1286
4.21		Overall width	b ₁	mm	1270	1270	1270
4.22		Fork dimensions	s/e/l	mm	40/100/1150*	40/100/1150*	40/100/1150*
4.23		Fork carriage ISO 2328, class/type A, B			II A	II A	II A
4.24		Fork-carriage width	b ₃	mm	850	850	850
4.25		Width over forks	b ₅	mm	250-738	250-738	250-738
4.26		Distance between support arms	b ₄	mm	900	900	900
4.28		Reach distance	l ₄	mm	613	613	541
4.31		Ground clearance, with load, below mast	m ₁	mm	70	70	70
4.32		Ground clearance, centre of wheelbase ¹⁾	m ₂	mm	70	70	70
4.33		Aisle width for pallets 1000 x 1200 crossways	A _{st}	mm	2706	2706	2758
4.34		Aisle width for pallets 800 x 1200 lengthways	A _{st}	mm	2749	2749	2814
4.35	Turning radius	W _a	mm	1668	1668	1668	
4.37	Length across support arms	l ₇	mm	1828	1828	1828	
Performance data	5.1	Travel speed, with/without load		km/h	10,0/10,0**	10,0/10,0**	10,0/10,0**
	5.2	Lift speed, with/without load		m/s	0,31/0,43	0,30/0,43	0,28/0,43
	5.3	Lowering speed, with/without load		m/s	0,49/0,52	0,51/0,52	0,52/0,52
	5.4	Reach speed, with/without load		m/s	0,20/0,20	0,20/0,20	0,20/0,20
	5.8	Max. gradeability, with/without load ¹⁾		%	15/18	12/20	11/18
	5.10	Service brake			Electric	Electric	Electric
Electric motor	6.1	Drive motor rating S2 60 min		kW	5,0	5,0	5,0
	6.2	Lift motor rating S3 15%		kW	10,0	10,0	10,0
	6.4	Battery voltage, nominal capacity K ₅		V/Ah	48/310*	48/465*	48/620
	6.5	Battery weight		kg	552	719	903
	6.6	Energy consumption acc to VDI cycle ²⁾		kWh/h			
	Other	8.1	Type of drive control			Variable AC	Variable AC
8.4		Sound level at the driver's ear according to EN 12 053		dB(A)	70	68	68

1) Measured according to company standard.

2) Contact your supplier for information.

*) Other alternatives are available.

***) Travel speed, with/without load, ANSI-model: 8,0/8,0 km/h.

All data are based on table configuration. Other configurations may give other values.

Truck performance and dimensions are nominal and subject to tolerances.

BT products and specifications are subject to change without notice.

Battery compartment

Dimensions				RRE120B		RRE140B		RRE160B	
Reflex	1.8	Depth		mm	275	275	275	347	347
	1.8	Load distance, centre of support arm wheel to face of forks without side shift	x	mm	453	453	453	381	381
			x	mm	415	415	415	343	343
			x	mm	404	404	404	332	332
	4.20	Length to face of forks without side shift	l_2	mm	1214	1214	1214	1286	1286
			l_2	mm	1252	1252	1252	1324	1324
			l_2	mm	1263	1263	1263	1335	1335
	4.33	Aisle width for pallets 1000x1200 crossways without side shift	A_{st}	mm	2680	2680	2680	2730	2730
			A_{st}	Mm	2706	2706	2706	2758	2758
			A_{st}	Mm	2714	2714	2714	2766	2766
	4.34	Aisle width for pallets 800x1200 lengthways without side shift	A_{st}	Mm	2715	2715	2715	2780	2780
			A_{st}	Mm	2749	2749	2749	2814	2814
			A_{st}	Mm	2759	2759	2759	2824	2824
	4.35	Turning radius	W_a	mm	1668	1668	1668	1668	1668
6.4	Battery voltage, nominal capacity K_5		V/Ah	310	465	465	620	620	
6.5	Battery weight, min.—max.		kg	485-590	660-785	660-785	845-995	845-995	

Mast dimensions, mm

Mast	Duplex Tele mast					Triplex Hilo mast												
	Lift height	h_{23}	mm	3000	3500	4000	4500	5000	4400	4800	5400	5700	6300	6750	7000	7500	8000	8500
Lift	h_3	mm	2960	3460	3960	4460	4960	4360	4760	5360	5660	6260	6710	6960	7460	7960	8460	
RRE120B	Height, mast lowered	h_1	mm	2050	2300	2550	2800	3050	2049	2182	2382	2482	2682	2932	3015	—	—	—
	Free lift	h_2	mm	—	—	—	—	—	1416	1550	1750	1850	2050	2300	2384	—	—	—
	Heigh, mast extended	h_4	mm	3550	4050	4550	5050	5550	5033	5432	6032	6332	6932	7382	7631	—	—	—
RRE140B	Height, mast lowered	h_1	mm	2050	2300	2550	2800	3050	2049	2182	2382	2482	2682	2932	3015	3223	3390	3556
	Free lift	h_2	mm	—	—	—	—	—	1416	1550	1750	1850	2050	2300	2384	2590	2756	2924
	Heigh, mast extended	h_4	mm	3550	4050	4550	5050	5550	5033	5432	6032	6332	6932	7382	7631	8133	8634	9132
RRE160B	Height, mast lowered	h_1	mm	2050	2300	2550	2800	3050	2049	2182	2382	2482	2682	2932	3015	3223	3390	3556
	Free lift	h_2	mm	—	—	—	—	—	1416	1550	1750	1850	2050	2300	2384	2590	2756	2924
	Heigh, mast extended	h_4	mm	3550	4050	4550	5050	5550	5033	5432	6032	6332	6932	7382	7631	8133	8634	9132

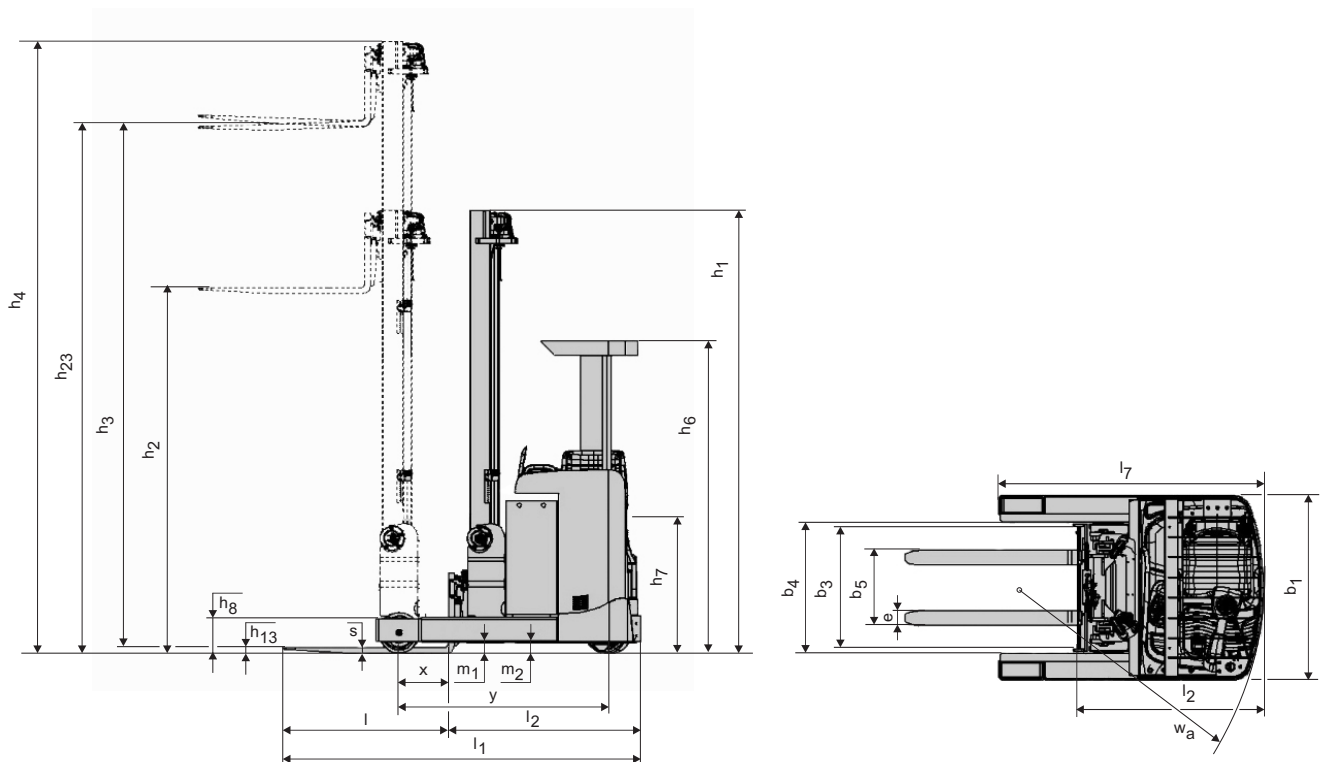

Truck features:

- Car pedal layout
- Automatic parking brake
- Single function levers
- Adjustable floor
- Duplex Tele mast — Panoramic View
- Triplex Hilo mast — Clear View

